

**ANNEX A**  
SI (Metric) Tables A2 through A7

**TABLE A2**  
90° Branch Outlets – Butt welding, SI (Metric) Units

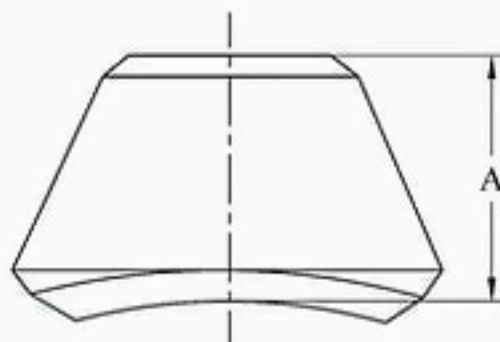

Dimensions in millimeters

Outlet (DN)	A (Face of Fitting to Crotch)							
	Standard		Extra Strong		Schedule 160		Double Extra Strong	
	Reducing	Full	Reducing	Full	Reducing	Full	Reducing	Full
6	15.7	--	15.7	--	--	--	--	--
8	15.7	--	15.7	--	--	--	--	--
10	19.1	--	19.1	--	--	--	--	--
15	19.1	19.1	19.1	19.1	28.4	28.4	28.4	28.4
20	22.4	22.4	22.4	22.4	31.8	31.8	31.8	31.8
25	26.9	26.9	26.9	26.9	38.1	38.1	38.1	38.1
32	31.8	31.8	31.8	31.8	44.4	44.4	44.4	44.4
40	33.3	33.3	33.3	33.3	50.8	50.8	50.8	50.8
50	38.1	38.1	38.1	38.1	55.4	55.4	55.4	55.4
65	41.1	41.1	41.1	41.1	62.0	62.0	62.0	62.0
80	44.4	44.4	44.4	44.4	73.2	73.2	73.2	73.2
90	47.8	50.8	47.8	50.8	76.2	76.2	76.2	76.2
100	50.8	50.8	50.8	50.8	84.1	84.1	84.1	84.1
125	57.2	57.2	57.2	57.2	93.7	93.7	93.7	93.7
150	60.4	60.4	77.7	77.7	104.6	104.6	104.6	104.6
200	69.8	69.8	98.6	98.6	--	--	--	--
250	77.7	77.7	93.7	88.9	--	--	--	--
300	85.9	85.9	103.1	100.1	--	--	--	--
350	88.9	88.9	100.1	104.6	--	--	--	--
400	93.7	93.7	106.2	112.8	--	--	--	--
450	96.8	103.1	111.2	119.1	--	--	--	--
500	101.6	117.3	119.1	127.0	--	--	--	--
600	115.8	136.6	139.7	139.7	--	--	--	--

**Tolerances:** DN 6 – 20      ±0.8 mm  
 DN 25 – 100      ±1.6 mm  
 DN 125 – 300      ±3.2 mm  
 DN 350 – 600      ±4.8 mm